



# quick & easy Router Table



▲ **Deluxe Version.**  
Basic router table with  
upgrades and optional stand.

This simple table will get you going, later add a few options for even more capabilities.

■ This router table is packed with some impressive features. But what I really like about it is that it takes only one 5' x 5' sheet of 1/2" Baltic birch plywood (see the cutting diagram on the next page) and a weekend to build.

**Large Top.** Fast construction isn't the only thing going for this router table. For starters, the top is a full 20" x 32". But there's more to it than pure size, the top tilts up for easy router access. The heavy-duty fence makes accurate cuts a snap. And it adjusts quickly and locks securely to the tabletop.

**Simple Joinery.** The case, built with simple, no-frills joinery, can be quickly

clamped to a workbench or even sawhorses. And there's a drawer at the bottom for storing bits, wrenches, and other items.

**Upgrades and Add-ons.** From the beginning, this router table is designed to be upgraded and added on to without having to start over. For instance, you can add an optional stand with either adjustable shelves or a door and some drawers (photo at left).

The tabletop and fence are also ready for some extra features, like a miter track, a router plate and T-track. And to top it off, at least around here, you can pick up the sheet of plywood for around \$50.



**1** FIGURE

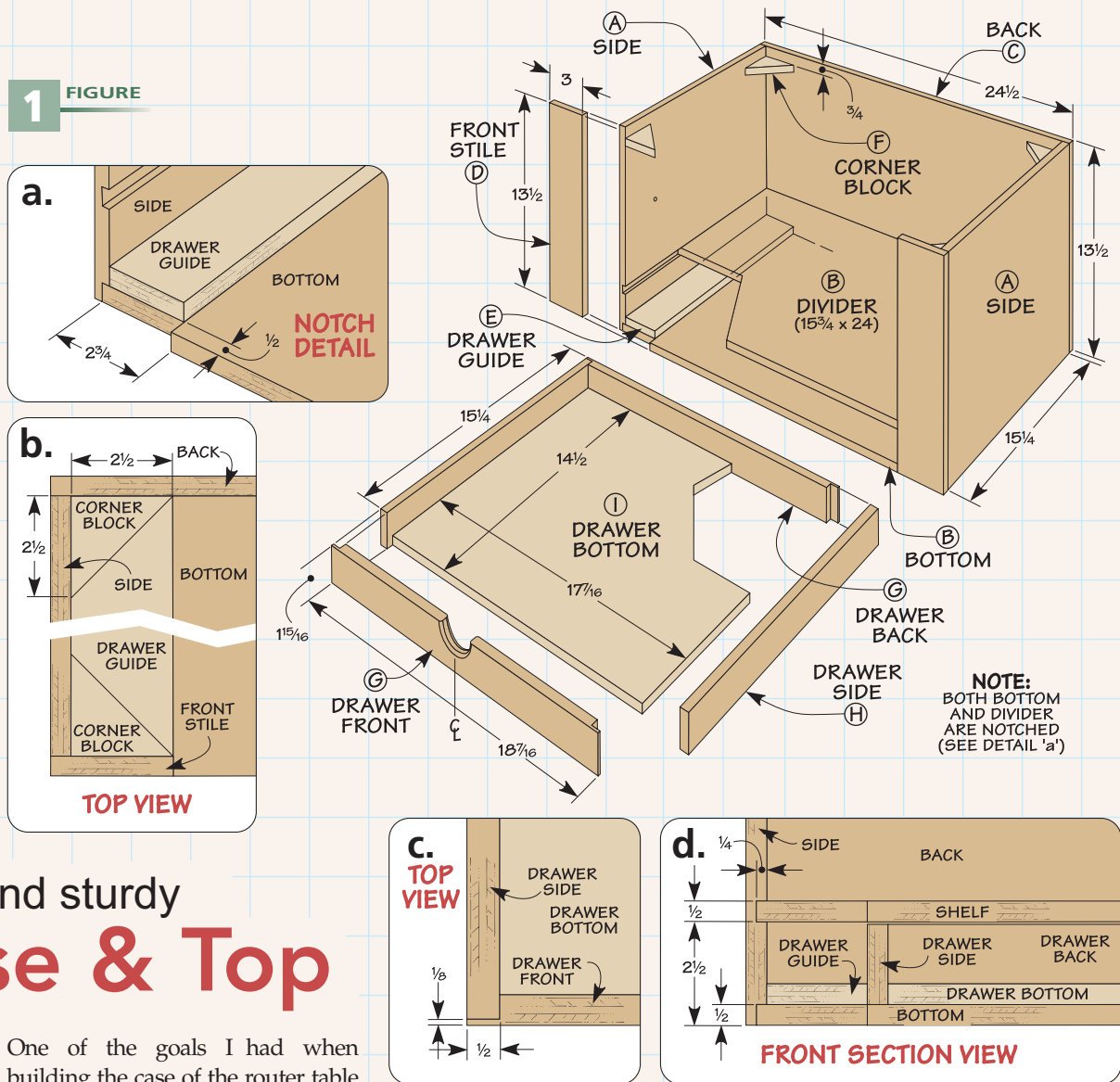

## strong and sturdy Case & Top

One of the goals I had when building the case of the router table was to make sure it could be built quickly. But it still needs to be strong enough for every day use.

**Straightforward Joinery.** As I mentioned earlier, the router table case uses sturdy plywood construction with dados and rabbets. The whole table is built from  $\frac{1}{2}$ " plywood. (I used Baltic birch.)

**Sides First.** I began construction with the case sides. In Figure 1d, you can see that there's a dado and a rabbet cut in each side piece. This joinery locks a divider and the case bottom in place for a strong, wiggle-free assembly. The divider also creates a pocket for the drawer that will be added later.

Before assembling the divider and bottom to the sides, I cut a  $2\frac{3}{4}$ "-wide notch at the front corners of each piece, as you can see in Figure 1a. This notch holds a pair of narrow

stiles that keep the front of the case rigid while still providing a large opening to get at the router.

The back is a simple plywood panel that's sized to overlap the sides. With these main parts cut, you can glue the case together.

**Corner Blocks.** The divider and case bottom make the lower portion of the case plenty strong. But since the tabletop isn't screwed to the case, the upper part of the case needed some reinforcement.

The solution I used here was to make four, angled corner blocks, as illustrated in Figure 1b. You can see in the main drawing that I positioned them  $\frac{3}{4}$ " from the top edge of the case. The reason for this is simple. The hinged tabletop is designed to nestle down over the top of the case, so lowering the

corner blocks ensures that they won't interfere with the fit.

There are just two parts left to add to the case before moving on to the drawer. And those are a pair of drawer guides. They're cut to fit behind the front stiles to keep the drawer from binding in the opening, as shown in Figures 1 and 1d.

**Simple Drawer.** The drawer in the router table provides a place to store wrenches, bits, and other supplies. And like the rest of the router table, it's straightforward to build.

In the drawing above, you can see that a rabbeted frame simply wraps around the drawer bottom. The relatively thick bottom provides plenty of glue surface for a strong bond.

**Large, Flat Top.** With the case complete, I set it aside and turned my attention to the top, shown in the



drawing below. Since this is where all the work will take place after the table is complete, the goal here is to make it flat and rigid.

Making a large top from plywood isn't a challenge — just cut it to size. But with  $\frac{1}{2}$ " plywood, you want to make sure it won't flex under the load of large, heavy pieces. So, to make this tabletop stay flat, it's reinforced around the bottom edge.

The top has a few openings cut into it. The center hole is where the router is attached to the table and

where the bits comes through. At 2" in diameter, it's big enough to handle most bit sizes.

The other two openings are a pair of slots that will be used to connect and adjust the fence that will be added later, as in Figure 2. To attach the router to the table, I simply screwed it to the top.

**Fillers and Braces.** As I mentioned, the top is strengthened with some cleats underneath it. Besides keeping the top from flexing, the cleats do one other thing. They are

positioned so that the top fits over the case like a lid, you can see this in Figures 2a and 2b.

**Tilt-Top Design.** Rather than screwing the top to the case, I attached it with a piano hinge along the back edge. This allows me to tilt up the tabletop and get at the router to change the bit height without having to stoop over.

Then, to hold the top open so I can use both hands, I bolted a prop arm to the inside of the case, as shown in the drawing and arm detail below.

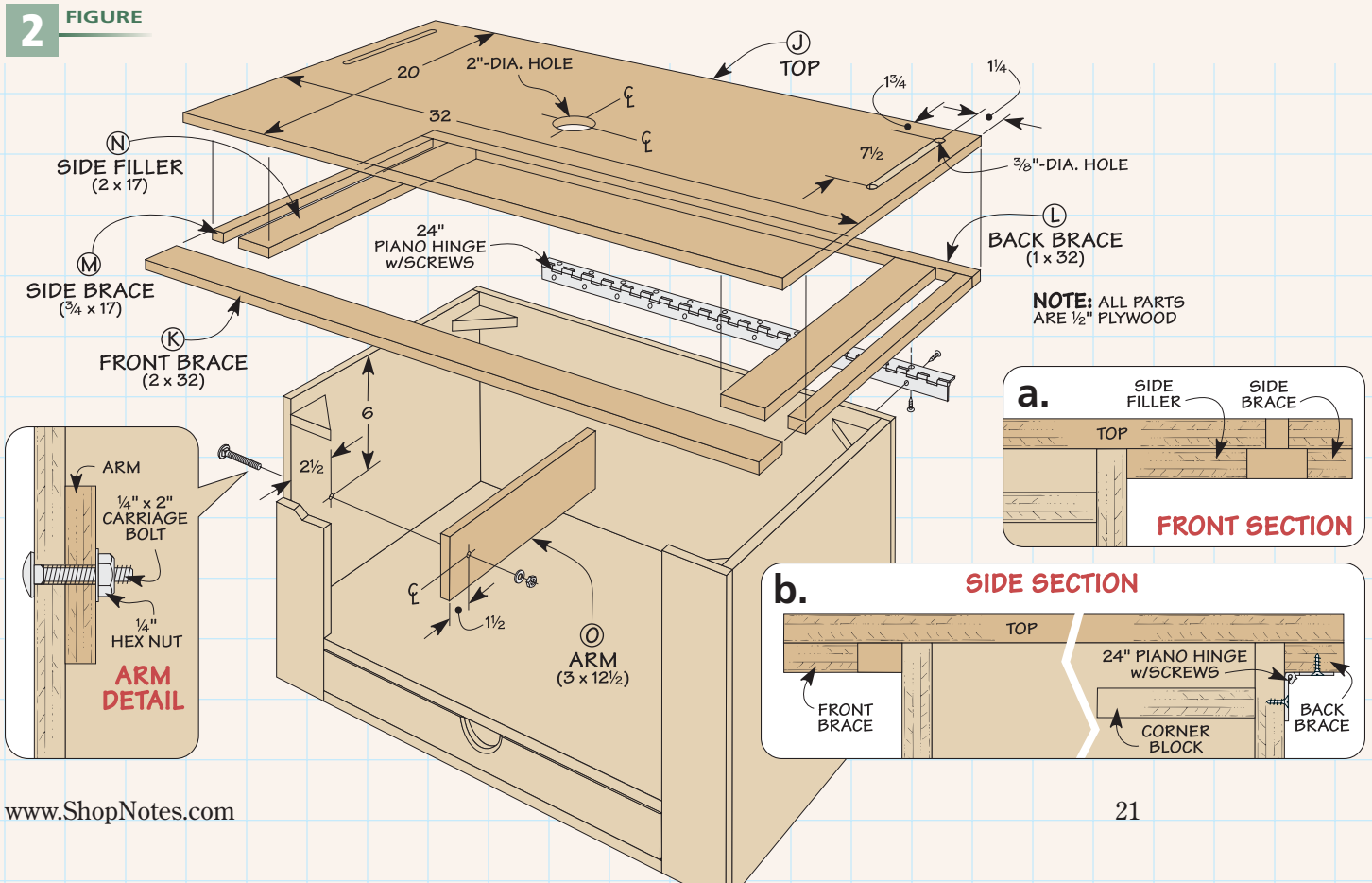

**3** FIGURE

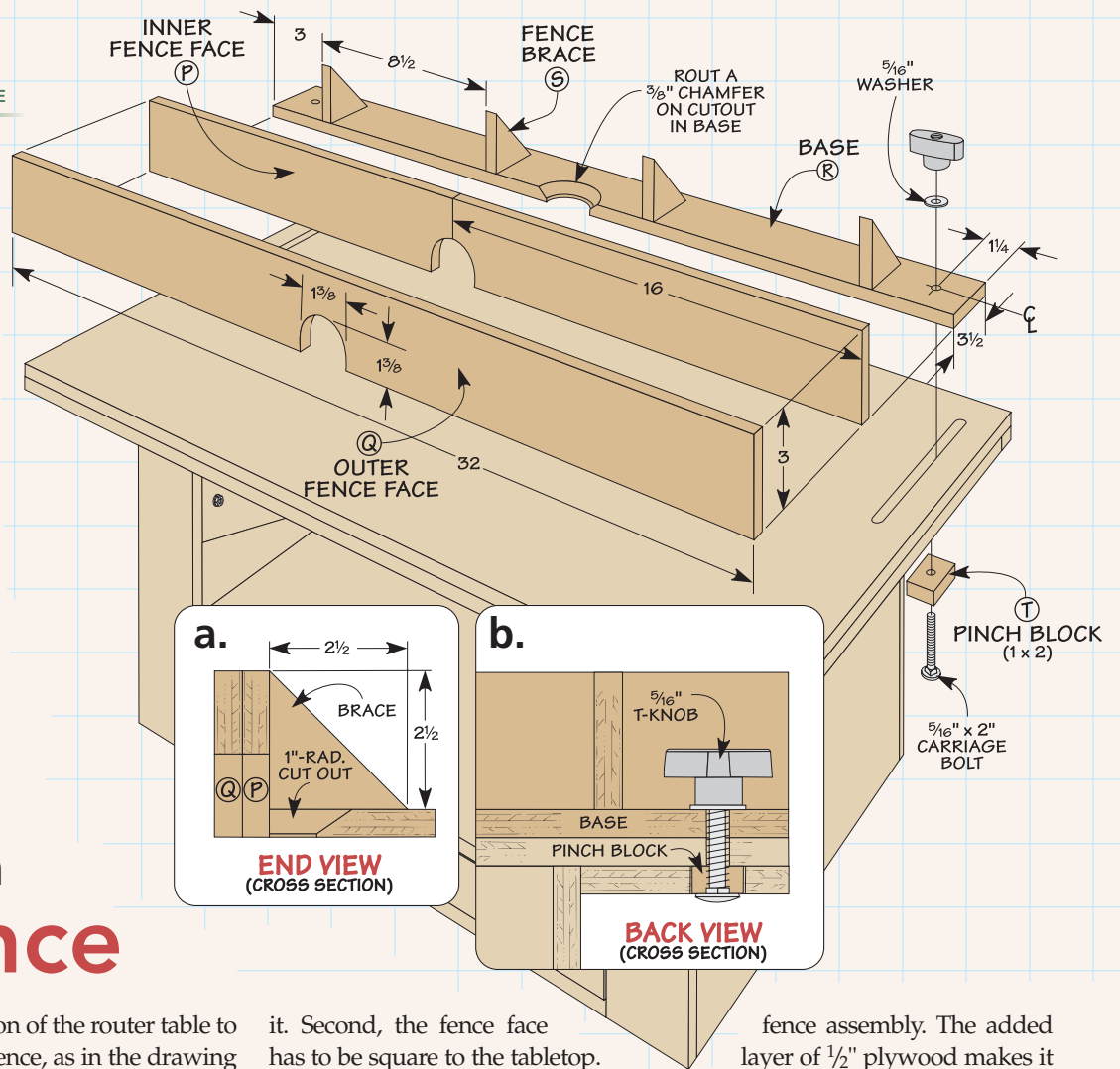

▲ **Router Fence.** Grooves in the router table allow you to easily position the fence and lock it securely to the tabletop.

## a precision Fence

The last section of the router table to make is the fence, as in the drawing above. And it's really what makes the router table a precision tool.

For the fence to work its best, it needs to do three things. First, the fence needs to be rigid so it won't deflect as a workpiece slides across

it. Second, the fence face has to be square to the tabletop. This way, you can be sure your cuts are accurate every time. Finally, it has to lock securely to the tabletop.

**Heavy-Duty Face.** The first step in building the fence is making the faces. Here, I used a double-layer

fence assembly. The added layer of 1/2" plywood makes it less likely to flex or warp.

You'll notice that the inside face of the fence is made from two pieces. I did this to get the most parts from a single sheet of plywood. A centered cutout in each layer is large enough to accommodate most router bits.

**Stable Base.** This assembly is then glued to a base that has a matching cutout. To help dust and chips clear this opening, I routed a chamfer on the cutout in the base (Figure 3a).

The joint between the fence and the base needed some reinforcement. I did this by gluing braces to the backside of the fence face.

**Attaching the Fence.** The fence is connected to the table with carriage bolts, washers, and knobs. The carriage bolts run through a pair of pinch blocks. These slide in the channel created by the reinforcing cleats on the bottom side of the table.

Now, the router table is ready for use. But on the next page, you'll find some options to get more out of it.

## Materials & Hardware

### CASE

A	Sides (2)	13 1/2 x 15 1/4 - 1/2 Ply.
B	Bottom/Divider (2)	15 3/4 x 24 - 1/2 Ply.
C	Back (1)	13 1/2 x 24 1/2 - 1/2 Ply.
D	Front Stiles (2)	3 x 13 1/2 - 1/2 Ply.
E	Drawer Guides (2)	13 1/2 x 2 1/2 - 1/2 Ply.
F	Corner Blocks (4)	2 1/2 x 2 1/2 - 1/2 Ply.

### DRAWER

G	Front/Back (2)	1 15/16 x 18 7/16 - 1/2 Ply.
H	Sides (2)	1 15/16 x 15 1/4 - 1/2 Ply.
I	Bottom (1)	14 1/2 x 17 7/16 - 1/2 Ply.

### TOP

J	Top (1)	20 x 32 - 1/2 Ply.
K	Front Brace (1)	2 x 32 - 1/2 Ply.
L	Back Brace (1)	1 x 32 - 1/2 Ply.
M	Side Braces (2)	3/4 x 17 - 1/2 Ply.
N	Side Fillers (2)	2 x 17 - 1/2 Ply.
O	Prop (1)	3 x 13 - 1/2 Ply.

### FENCE

P	Inner Faces (2)	3 x 16 - 1/2 Ply.
Q	Outer Face (1)	3 x 32 - 1/2 Ply.
R	Base (1)	3 1/2 x 32 - 1/2 Ply.
S	Braces (4)	2 1/2 x 2 1/2 - 1/2 Ply.
T	Pinch Blocks (2)	1 x 2 - 1/2 Ply.

- (1) Nickel-plated piano hinge w/Screws
- (1) 1/4" x 1 1/4" Fh Woodscrews
- (1) 1/4" Flat Washer
- (1) 1/4" Lock Nut
- (2) 5/16" x 2" Carriage Bolts
- (2) 5/16" Flat Washers
- (4) 5/16" T-Knobs

# router table Upgrade

There isn't much you can't do with the basic router table and fence. But you can make it work even harder and more efficiently with a few, simple upgrades (photo at right). The best part is, you can build the tabletop, and fence, as shown in the plans and then add any or all of these upgrades at a later time.

**Router Plate.** The tilt-up tabletop makes it easy to get at the router. But you can make router access even easier with a mounting plate. This is especially handy for bit changes and removing the router for hand-held use.

The router plate shown in the photo above also has drop-in insert rings. They let you match the size of the opening to the size of the bit. The plate rests in a rabbeted opening in the top. You can read more about installing it on page 16.

**Miter Track.** Another tabletop addition is a miter gauge slot. With

▶ **Easy Upgrades.** A miter track, router plate, and T-track add versatility to the router table.

this, you can use a standard miter gauge on your router table to rout the ends of narrow workpieces. The only thing to note here is that you'll need to add a reinforcing strip to the underside of the table, as shown in detail 'b.'

**T-track.** On the fence, there are two upgrades that really make a big impact. The first is to add T-track along the top edge. With this,

attaching bit guards, featherboards, and stop blocks is a snap.

**Dust Collection.** The final addition is to screw a dust collection port to the back of the fence. This is a big way to improve visibility and clear the shop air, as shown in detail 'a.' Turn to page 51 to find sources. You can find other router table accessories on page 8. 🛠️

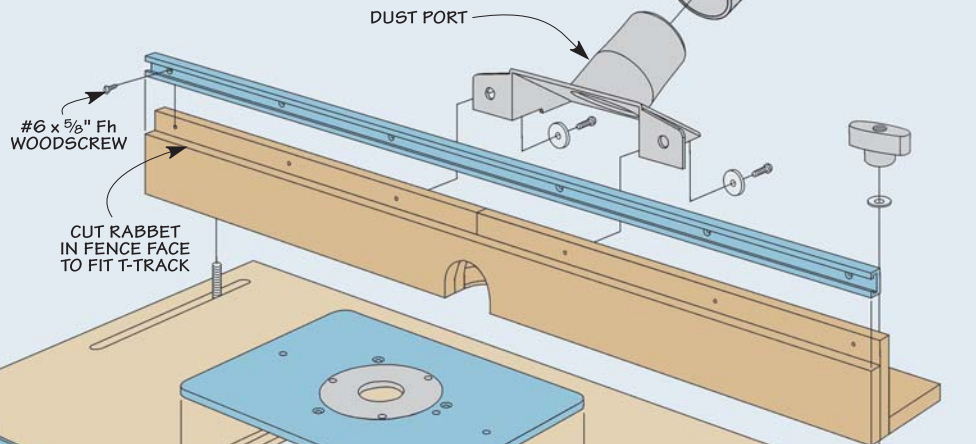
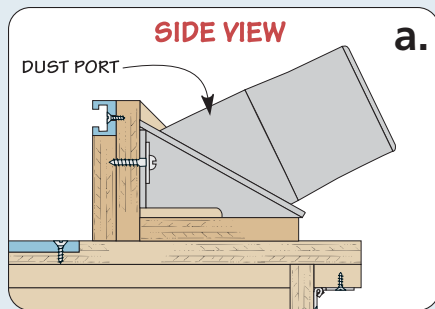

**NOTE:** FOR MORE ON DUST COLLECTORS SEE PAGE 8

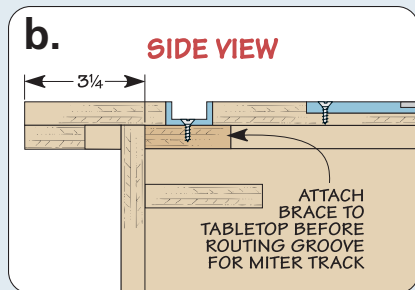

Ⓢ  
**MITER TRACK BRACE**  
(2 x 2 3/2)

**NOTE:** SIZE MITER TRACK BRACE SO TOP STILL CLOSES FLAT AGAINST CASE

optional tool

# Stand

There's nothing stopping you from putting the router table to use just the way it is. And it's small size makes it portable enough to take to a job-site. But for routing in the shop, it might make sense to have a dedicated stand like you see in the photo at right. This simple stand captures the router table in a ledge around the top and places the tabletop up to a comfortable height. And you'll gain some valuable storage space.

You'll find the process of building the stand pretty similar to the router table. And like the router table, the stand only requires a single sheet of  $\frac{1}{2}$ " plywood.

**Case Sides First.** To build the stand, I started by cutting the sides to size. These have two dados cut in them to hold the top and bottom panels (Figure 4b). And a rabbet cut along the back edge of each side holds the case back in place.

Next, I cut the top and bottom panels to size. These have a centered dado that captures a vertical divider. After dry assembling the



sides, top, and bottom, you can double check the measurements for the divider and cut it to fit.

To reinforce the bottom of the case, I made a toe kick and a pair of cleats to fit under the case bottom. The last thing to do before assembling the case is to cut a back to fit

between the rabbets in the case sides, as shown in Figure 4a.

**Shelves and Supports.** There are just a couple details left to wrap up the stand. I cut three shelves to size. And finally, I drilled a set of shelf pin holes in the sides and divider to support the shelves. 

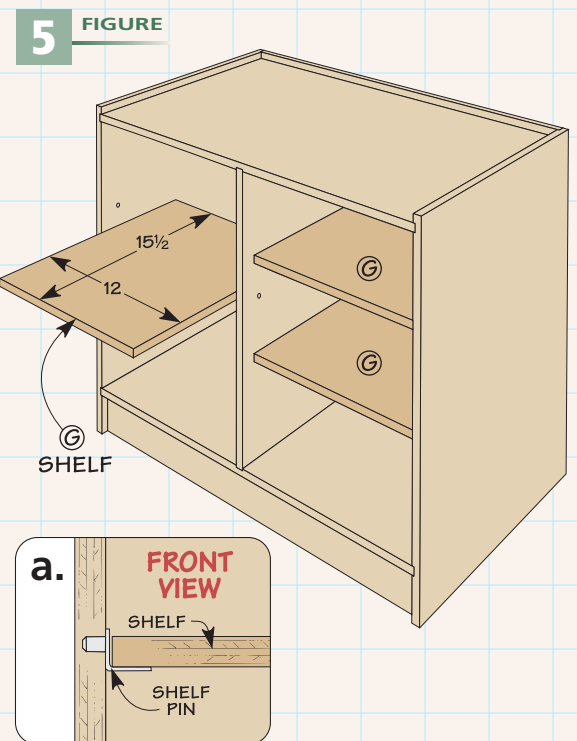
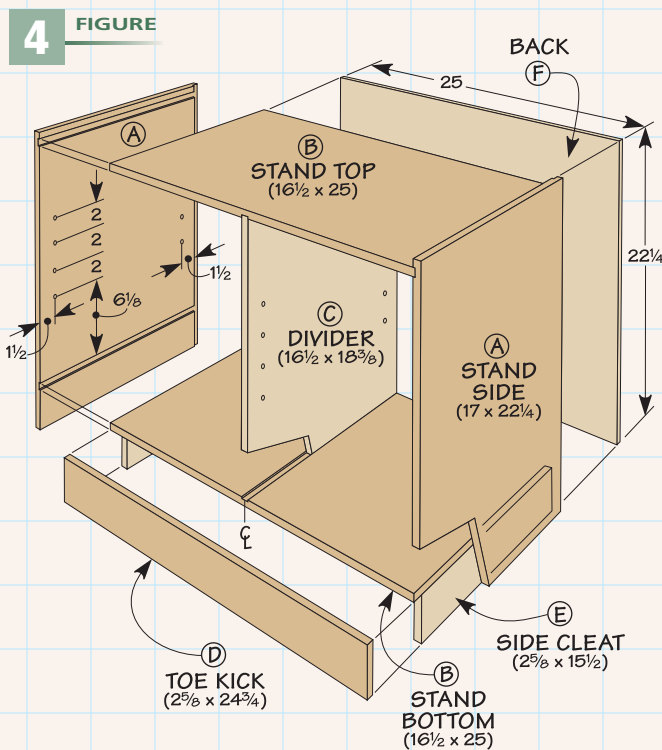
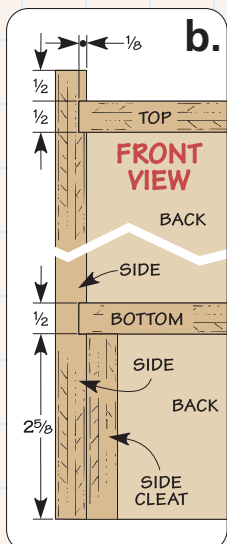
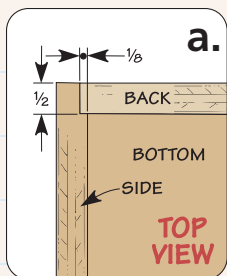

# Upgraded Stand

It's pretty amazing that you can build the stand shown on the opposite page from a single sheet of plywood. And not only does it raise the router table up to a comfortable working height, it adds a lot of storage for the accessories that routers tend to accumulate.

But like the tabletop and fence, you can also take the stand up a notch. And all it takes is another sheet of  $\frac{1}{2}$ " plywood. You can see what I added in the drawing below and the photo at right. At first glance, making a few drawers and door may not seem like a big improvement, but I found that it was more than worth the effort.

With the drawers, you can easily find and get at the small tools, bits, and accessories that usually find their way to the back of the shelves. Another benefit of the drawers and door is that it blocks out dust.

**Making the Door.** The door is about as easy as it gets. It's simply cut to size and then a cutout is made for a handle. The door is mounted on self-closing hinges.

**Drawers.** The drawers in the stand follow pretty much the same construction as the small drawer in the



router table. But there's an important differences. The drawers ride on thin guides that are cut from plywood and screwed to the stand (detail 'd' and drawer guide detail). The guides fit in grooves that are cut in the drawer sides before assembly. Finally, a matching notch is cut in the drawer back in order for the drawers to slide in place, as illustrated in detail 'c.'

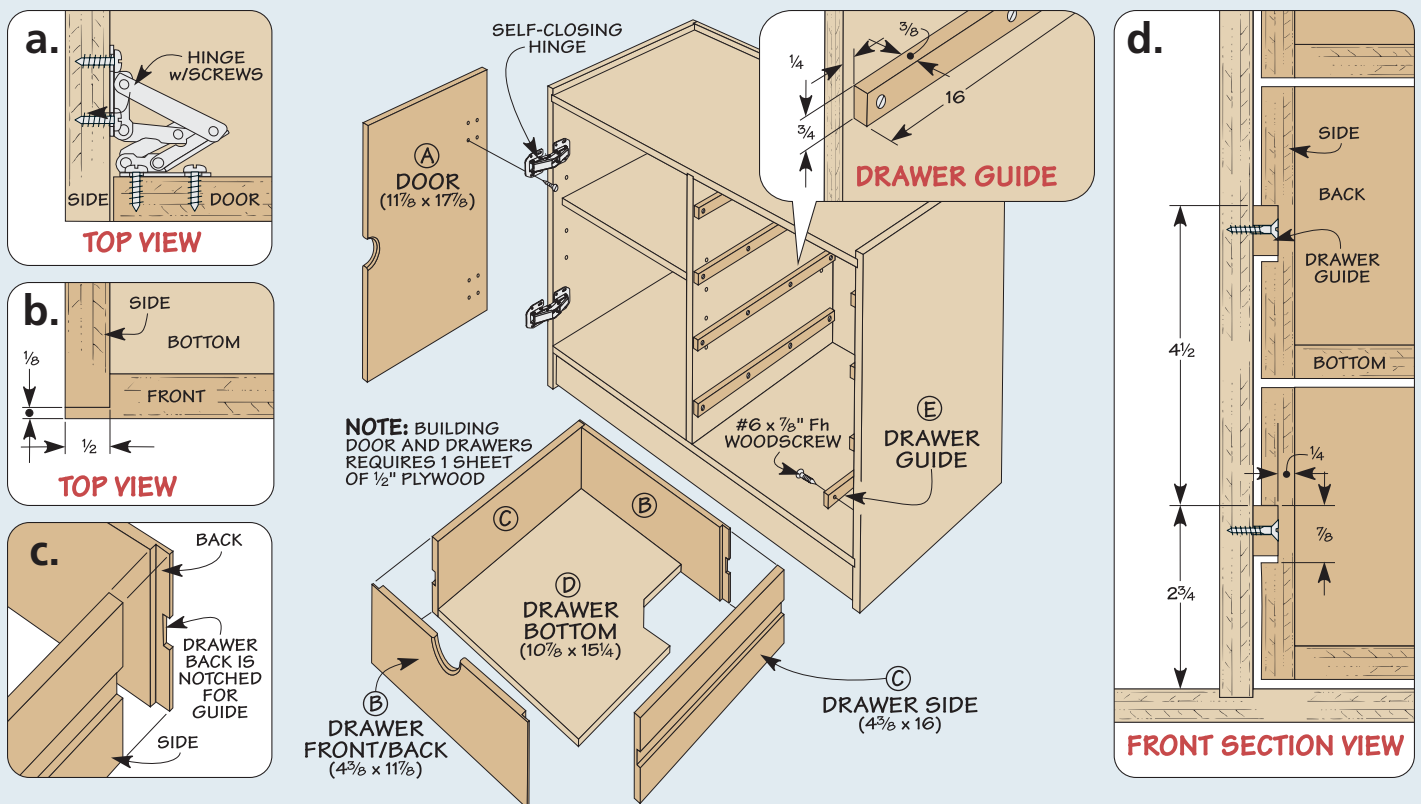

# Corrections

There are corrections on file for this article ( **Quick & Easy Router Table** from *ShopNotes No. 85 (January 2006)* ). Please compare this list of corrections to the article content.

- the **Materials & Hardware** (page 22):  
Dimensions of piece E - Drawer Guides printed as 13 1/2 x 2 1/2 - 1/2 ply., but it should be 15 1/4 x 2 1/2 - 1/2 ply.

## Thank you for your interest in August Home Publishing!

If you have questions about this article please contact us at [orders@augusthome.com](mailto:orders@augusthome.com) or 1-800-333-5441.

All content in this document ©August Home Publishing. All rights reserved.