

all about the Leigh Super Jig

Whether it's variably spaced dovetails or precision box joints, this new jig has it all covered and then some.

■ A number of years ago, we featured an article on the *D4* dovetail jig from Leigh. It's one of the premier dovetail jigs on the market. And for good reason — it can handle just about any dovetail task you could think of. Its only real downside was the cost of about \$400. Check out the margin for more information on getting the original article on the *D4*.

To bring many of the benefits and features of the *D4* to a larger woodworking audience at a lower cost, Leigh has introduced its line of *Super Jigs*. The 18" model is shown below, but Leigh has 12" and 24" versions available, as well.

A quick look below covers most of the key features. The most notable differences between the *D4* and

the *Super Jig* are in the design of the fingers that control the spacing and layout of the dovetails, and the unique *E-Bush* (more on this later).

The Finger Assembly. The single-finger design of the *Super Jig* still allows for customizing the look of your dovetails, whether you're cutting half-blind or through dovetails. You can cut variably spaced and sized dovetails however you'd like.

Fixed Pin Size. Your only real limitation is the size of the pin. It's fixed for each dovetail bit you use with the jig. So is that a problem? Not in my opinion. I'm usually more interested in the variation of the size and spacing of the tails, not the size of the pins.

Production Option. Okay, so it cuts great custom dovetails. What else does it have going for it? Well, if you need to make a lot of half-blind drawers, you can set up the *Super Jig* to cut both parts of the joint at one time. That's something new for any of the Leigh jigs.

To do this on the *Super Jig*, each finger is drilled to accept a flexible rod that limits the travel of the router bit. This turns the overall finger assembly into a "fixed template," like you see on inexpensive half-blind dovetail jigs.

Adjustment. Regardless of the type of dovetails you cut, the setup starts with positioning the finger



For a copy of the original article on the Leigh *D4*, take a look at our website: ShopNotes.com

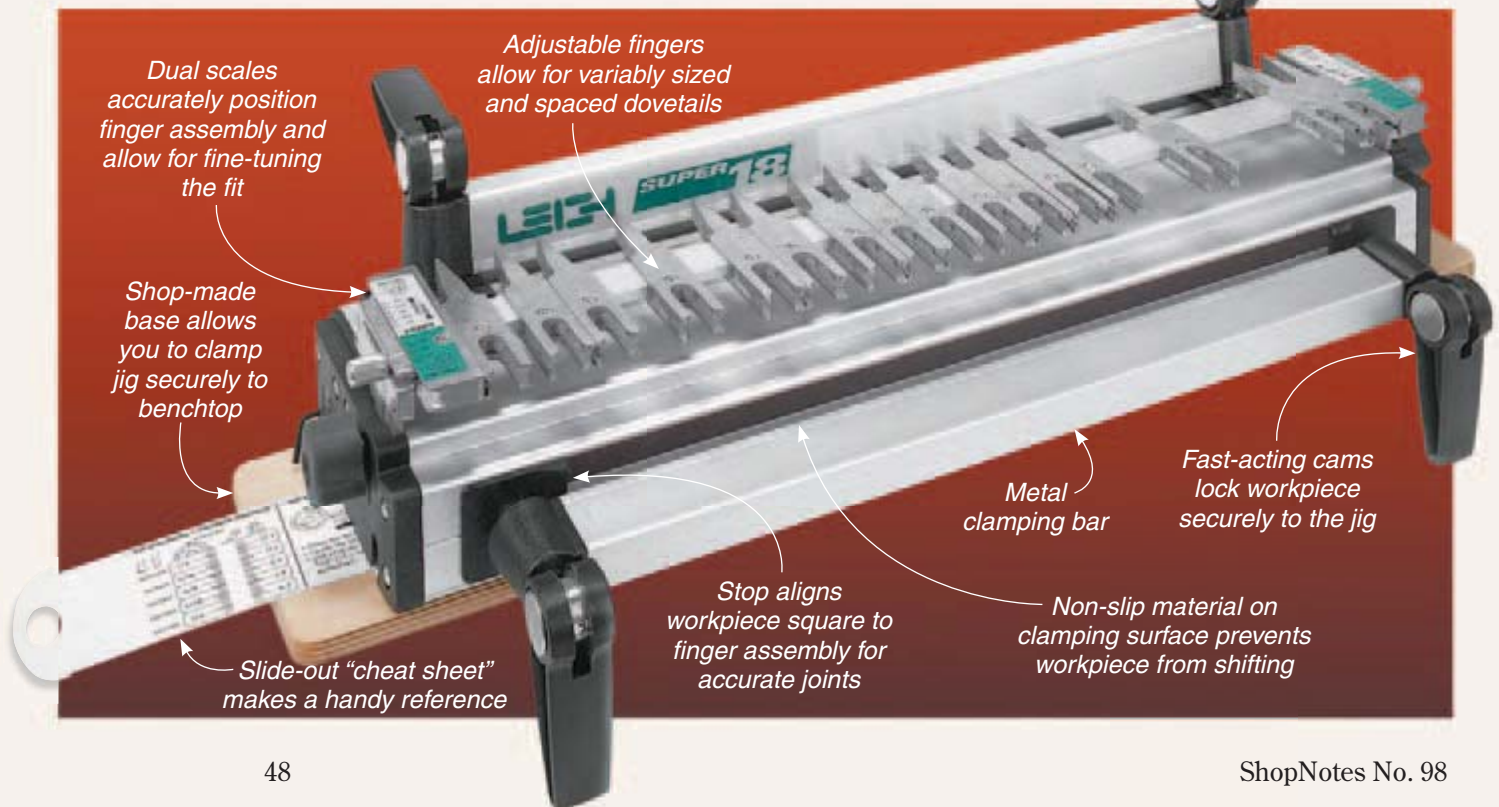

Dual scales accurately position finger assembly and allow for fine-tuning the fit

Adjustable fingers allow for variably sized and spaced dovetails

Shop-made base allows you to clamp jig securely to benchtop

Slide-out "cheat sheet" makes a handy reference

Stop aligns workpiece square to finger assembly for accurate joints

Metal clamping bar

Fast-acting cams lock workpiece securely to the jig

Non-slip material on clamping surface prevents workpiece from shifting



▲ **Scales.** A precision dual scale at each end of the assembly helps align the fingers and allows you to “dial-in” in a perfect fit.



▲ **Fingers.** To customize the size and spacing of the dovetails, just slide the fingers into position and lock them securely in place.

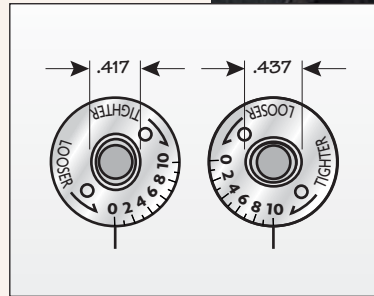
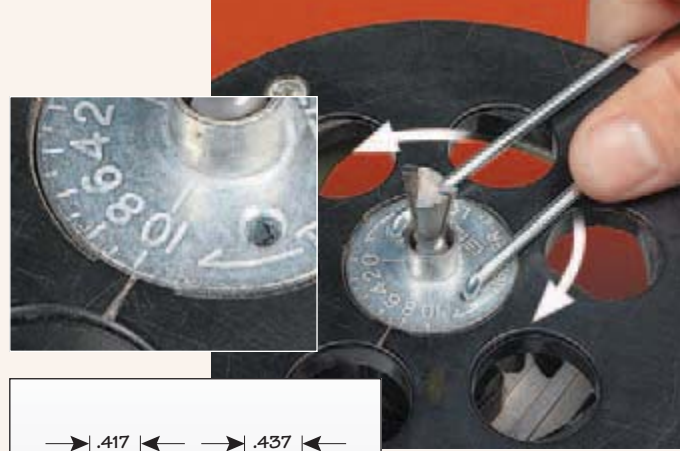

▲ **E-Bush.** By rotating the E-Bush on the router, you can “tweak” the fit of box joints, sliding dovetails, and even half-blind dovetails.

assembly and individual fingers to suit the task at hand.

Like the *D4*, the finger assembly on the *Super Jig* is reversible. With the green portion of the scales forward, you’re set for half-blind dovetails (left photo above). And with the white portion forward, through dovetails are only a few steps away. These scales make the overall setup a simple task.

If you take a look at the photo to the right above, you’ll note that all it takes to fix the arrangement of the fingers is to slide them where you want them and then lock them in place with the screwdriver supplied with the jig. Once you rout the tails and pins, you’ll find that everything matches perfectly.

Box Joints. Besides dovetails, the *Super Jig* is a great choice for routing box joints. With the same assembly, $\frac{5}{16}$ " and $\frac{5}{8}$ " box joints are a snap. And in the box below, you can learn more about an accessory template that will handle a wider range of box joint sizes.

The E-Bush. As if all this wasn’t enough, *Leigh* includes its latest innovation with the package. And that’s the new *E-Bush*.

Unlike a standard router bushing that’s symmetrical, the *E-Bush* is actually a bit elliptical in shape, hence its name. You can see what I’m talking about in the photos and drawings above.

What the *E-Bush* allows you to do is “tweak” the fit of your box joints

until they fit perfectly. All you need to do is rotate the *E-Bush* slightly. As you do this, you essentially make the cutting path narrower or wider. And since you never have to adjust the router bit, fine-tuning any joint is quick and easy.

Cost. You’d think that since a *Super Jig* has so many capabilities, it probably isn’t all that much less to own, right? Well, you can buy a *Super Jig 12"* model for just under \$200. And the 18" and 24" models run \$270 and \$370, respectively. Not a bad deal for all the capability built into the *Super Jig*.

The *Super Jigs* and optional accessories are available through many woodworking stores and catalogs. For sources, turn to page 51. 🛠️

Box Joint Add-On: Adjustable Template

To expand the range of box joints sizes you can create with the *Super Jig*, all you need is the specialized box joint template at right. Like the basic jig, it uses an *E-Bush* to guide the router and control the fit of the joint. But instead of one *E-Bush*, you get a pair.

One *E-Bush* is used with the $\frac{3}{8}$ " side of the template, and the other is used with the $\frac{1}{2}$ " side. With the two *E-Bush* options and the dual-sided

template, you can rout box joints in the following sizes: $\frac{3}{32}$ ", $\frac{1}{8}$ ", $\frac{3}{16}$ ", $\frac{1}{4}$ ", $\frac{3}{8}$ ", and $\frac{1}{2}$ ". The precision machining of the assembly makes this possible. A pin that slides along the template allows you to shift the fingers precisely to cut the mating slots of each box joint.

This template is just going into production. So the best option for availability and pricing is to check the *Leigh* website at leighjigs.com.



▲ **A Range of Box Joints.** Rout different size box joints with an adjustable template and two different *E-Bush* options.

MACHINE-CUT DOVETAILS

With a router and a dovetail jig you can cut a perfect-fitting joint in seconds. The trick is getting the jig set up properly.

I still remember the first time I used a dovetail jig. I don't know if it was the high-powered scream of the router, the shower of chips, or the rhythmic motion of moving the router in and out around the template, but I was hooked. For the next few months, I used dovetails on just about every project I made.

Although that initial excitement has subsided a little, I still think a dovetail jig is a great accessory for any shop. I can't imagine building the chest-on-chest featured in this issue without one. For speed and accuracy, a dovetail jig is hard to beat.

But there's more to cutting dovetails than simply flipping the switch on your router. The jig and router requires a careful setup. Plus, you'll need a couple test pieces to "fine-tune" the fit. Fortunately, this isn't too dif-

ficult. All it takes is a little patience and perseverance.

HALF-BLIND JIGS. There are several kinds of dovetail jigs on the market designed to cut a variety of dovetails. But one of the more common types is that which cuts half-blind dovetails, see box below. (Half-blind dovetails are often used on drawers where you don't want the dovetails to be visible from the front.)

All half-blind dovetail jigs work in the same fashion, see series of photos at right. The two workpieces are clamped in the jig at a right angle. Then a comb-like template is placed over the workpieces. A bushing on the router base (or sometimes a bearing on the router bit) guides a dovetail-shaped bit around the "fingers" of the template, cutting both the pins and the tails at the same time.



▲ **Clamp pieces in jig.** After positioning both workpieces underneath the jig template, tighten down the cams on the clamping bars to hold the workpieces securely in place.



▲ **Rout dovetails.** The template guides the router in and out as the dovetails and pins are routed simultaneously. This ensures a perfectly-aligned joint every time.



▲ **Test fit.** With the pieces removed from the jig, test the fit of the joint. The tails should slide halfway into the sockets. A soft mallet can then be used to drive the joint home.

HALF-BLIND DOVETAIL JIGS

While there are a number of half-blind dovetail jigs on the market, they all work in the same manner. The main



differences lie in the type of clamping system (some use cams, others use wing nuts), the material used for the template (plastic or metal), and the ease of adjusting the stops.

A bare-bones jig can be purchased for as little as \$60 while heavier-duty versions sell for \$300 to \$350.

Editor's Note: Although we used the Woodsmith dovetail jig for this article, the procedure is nearly identical for all half-blind dovetail jigs of this type.

The template controls the spacing of the dovetails. Most templates are designed to cut $\frac{1}{2}$ "-wide dovetails spaced $\frac{7}{8}$ " apart. So it's best to plan your projects so the width (height) of the drawers is always a multiple of $\frac{7}{8}$ ". This way, you'll end up with a joint that is symmetrical — a perfect half-pin on both the top and the bottom, see drawing in margin.

TEST CUTS. The template may control the spacing of the dovetails, but there are still a couple of adjustments that you'll have to make to control the fit of the joint. And since you don't want to risk ruining your finished workpieces, you'll need to practice on a couple of test pieces that are the same width and thickness as your drawer pieces. Then once you get the settings just right, you can rout the dovetails on your actual workpieces.

SETTING UP THE JIG. Essentially, there are three different adjustments that you'll need to be concerned with when setting up the jig.

First, a "stepped" stop on each end of the jig is used to create an offset between the two workpieces and to position them from side-to-side underneath the template. (On some jigs, this offset is created by using two separate stops.) This stop ensures that the dovetails are centered on the width of the workpieces (leaving equal-sized half-pins at the top and bottom).

When you're making a drawer or box, half the joints are cut on the left side of the jig and half are cut on the right side. (This way, the bottom of the workpiece is always against a stop.) So you'll have to set the stop at each

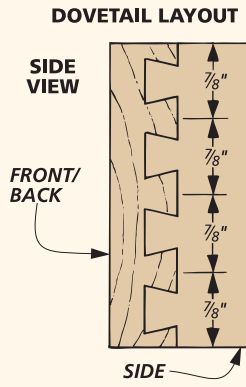
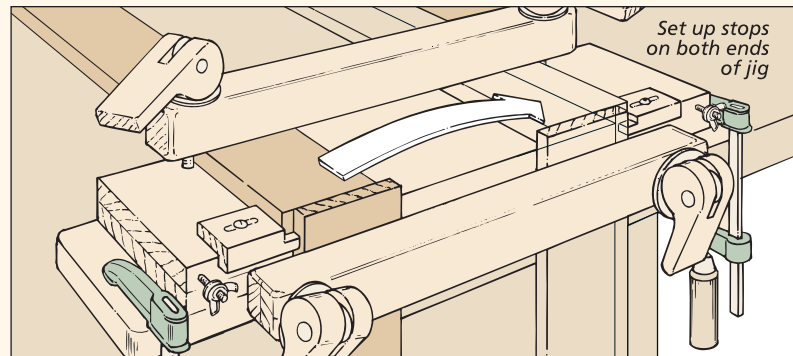
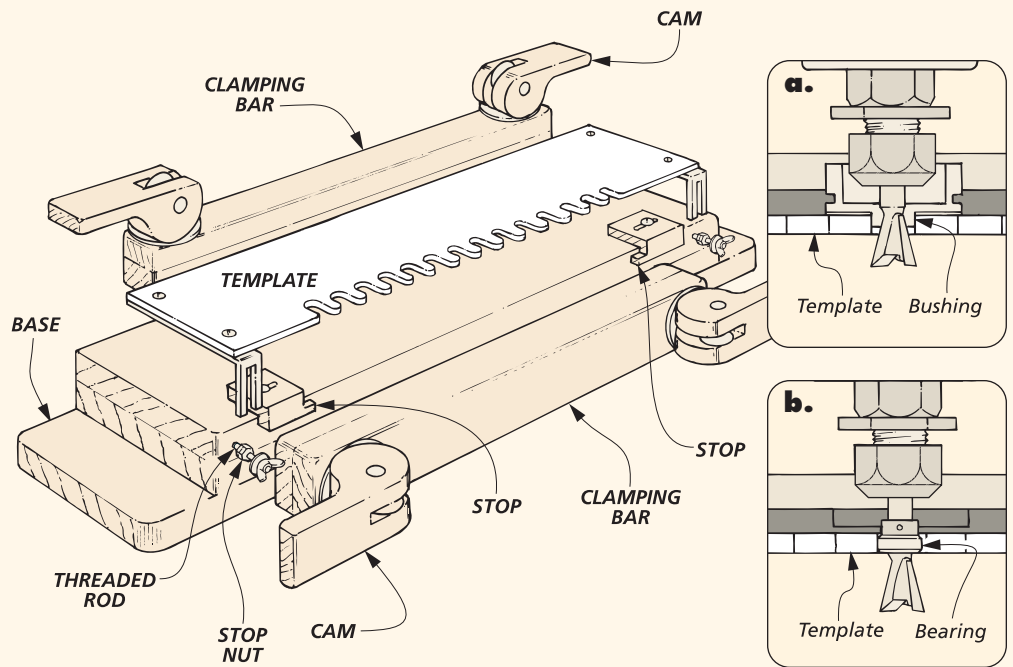

1 The stops on the ends of the jig are used to create a $\frac{1}{16}$ " offset between the two workpieces and to position them from side-to-side

beneath the template. You'll need to adjust each end of the jig independently, since half the joints are cut on the left and half on the right.

end independently, see Step 1.

The second adjustment to make is to the template. Two stop nuts on the threaded rods control the front-back positioning of the template, which affects the depth of the *sockets*. (The sockets are the spaces into which the dovetails fit.)

And finally, raising or lowering the height of the dovetail bit in the router controls the fit of the dovetails.

Later, you'll fine-tune each of these adjustments. But for now, you just want to get them "in the ballpark" so you can make your first test cut, see Steps 2 through 4.

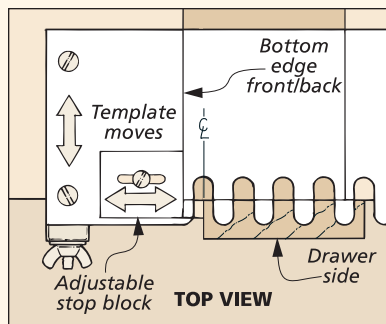

2 With the test pieces in the jig, adjust the stop so the edge of the front test piece is centered in the first notch or opening of the template.

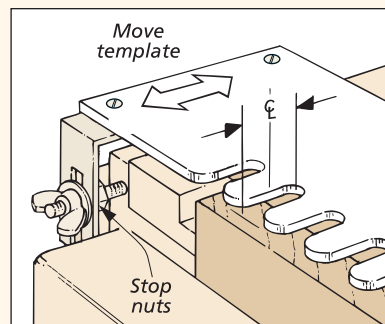

3 Stop nuts should be adjusted in or out so fingers of template are centered over the "joint line" between the two test pieces.

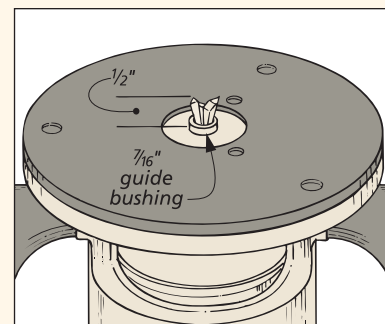

4 Mount $\frac{7}{16}$ " guide bushing onto router. Then to start with, raise bit $\frac{1}{2}$ " from router base. It may have to be adjusted slightly later on.

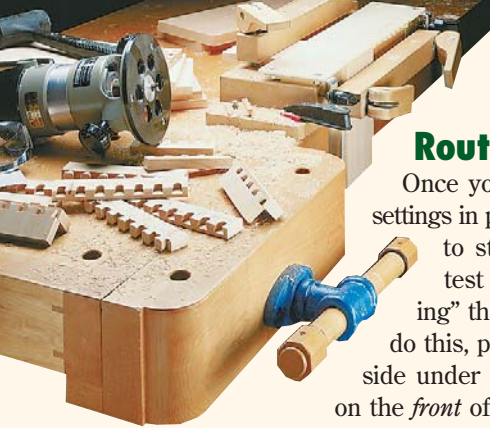

Rout Test Pieces

Once you have the initial settings in place, you're ready to start making your test cuts and "tweaking" the adjustments. To do this, place a test drawer side under the clamping bar on the front of the jig and a test drawer front under the clamping bar on top of the jig.

▲ To get a perfect-fitting joint, you'll need to rout a few test pieces first.

Make sure that both pieces are tight against the stops and the end of the drawer side piece is flush with the top face of the drawer front piece. (This is also important when it comes to routing the dovetails in your actual workpieces.)

ADD TEMPLATE. Next mount the template on the jig. Hold it down flat on the workpieces while you tighten the wing nuts. Check to make sure the template is resting flat and isn't flexed by the workpieces (especially if your template is plastic).

ROUT THE TEST PIECES. Now the pieces can be routed. To prevent chipout, start by making a *light* scoring pass from right to left, see Step 5. Safety Note: It's normally not a good idea to rout in this direction (backrouting). But it's okay in this case since you are taking just a light pass.

After the initial scoring cut, start gently moving the router in and out of the fingers, beginning on the left-hand side of the jig, see Step 6. You should be able to feel the guide bushing stop at the back of each notch.

Let the bushing and the template guide the router. You want to keep the bushing in contact with the edge of the template, but you don't need

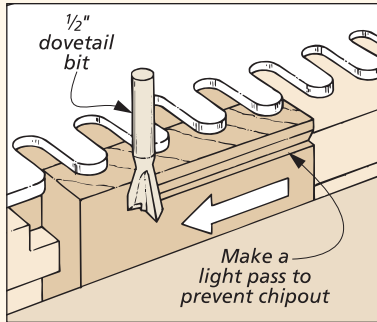

5 To prevent chipout on the drawer side, start by making a light pass from right to left. This skim cut establishes a clean shoulder line.

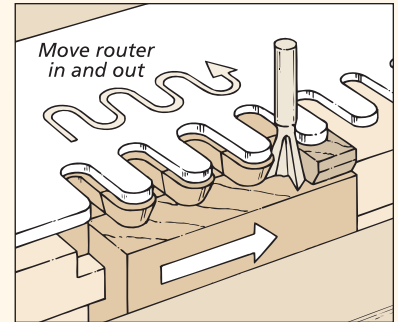

6 Next, move the router from left to right in and out of the notches. Push the router into each notch until the bushing hits the back of the notch.

to force it. Shop Tip: To help the router glide smoothly over the template, try applying a little paste wax to the router base and the template.

One other thing. When you're routing the dovetails, be careful to keep the router base flat on the template at all times. If you accidentally tip the router or lift it up, the bit will take a chunk out of your dovetails, your template, or both. (This is not good.)

REMOVE TEMPLATE. When you've finished routing the dovetails in the test pieces, turn off the router and remove the template to examine the dovetails. It's a good idea to leave the pieces in the jig until after you've checked to make sure that you've routed every pin and socket cleanly, see Step 7. This way, if you miss a spot you can simply place the template back on the workpieces and clean up the area you missed.

TEST FIT. Now you can remove the test pieces from the jig and see how they fit. Before fitting the pieces together, though, take a second to blow out any chips in the sockets

and lightly sand off any wood fibers remaining on the pieces, see Step 8.

Slide the pieces together to see how they fit, see Step 9. Ideally, you should be able to slide the dovetails about halfway into the sockets by hand. Then a light tap or two with a mallet should fully seat the tails.

Don't worry if the fit isn't perfect on the first try. Chances are you'll have to make some adjustments to the jig or the router bit (or both), see box on opposite page.

The important thing is to avoid trying to adjust everything in one fell swoop. Instead, focus on one thing at a time and keep making test cuts until you get it right. Shop Note: You can re-use your test pieces by simply trimming the dovetails off the ends.

Once you're satisfied with the fit, try cutting a test joint on the right side of the jig as well to make sure the stop on this end is positioned correctly. (You shouldn't have to change the bit setting or the stop nuts for the template.) Now you're ready to rout the dovetails on your actual pieces.

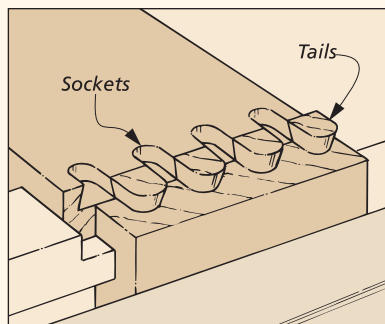

7 Finally, remove the template (but not the workpieces) and check to make sure that all of the dovetails and sockets are uniform.

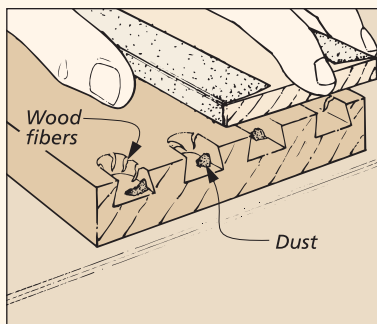

8 Before testing the fit of the joint, blow out any remaining wood chips and sand off any "whiskers" that are still attached to the pieces.

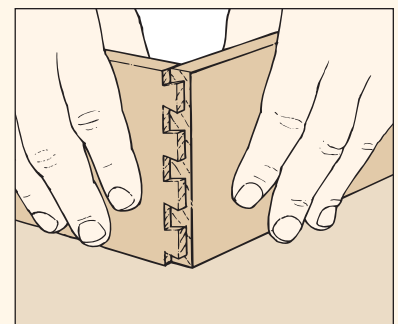

9 The dovetails should easily fit into the sockets about half way. A couple of taps with a mallet should drive them in the rest of the way.

Route Drawer Pieces

The procedure for routing the dovetails on the final workpieces is the same one that you used for routing your test pieces. But this is where all your patience in adjusting the jig pays off. Now it's just a matter of clamping each piece in the jig and routing the dovetails. The only trick is keeping all the drawer pieces organized as you go along.

LAY OUT JOINTS. To help keep things straight, I like to start by laying out all four drawer pieces on top of my bench, with the *inside* faces up, see detail 'a.' Then I number the matching corners (starting at the left, front corner) and label each piece (front, back or side). Finally, label or mark the bottom edge of each piece.

When you've got all the pieces labeled, you're ready to start routing the first corner. There are two main things to remember when placing the pieces in the jig. First, the pieces are always inserted so the inside faces out. And second, the bottom edges should always be against the stops. This means that you have to cut half the joints on the left side of the jig

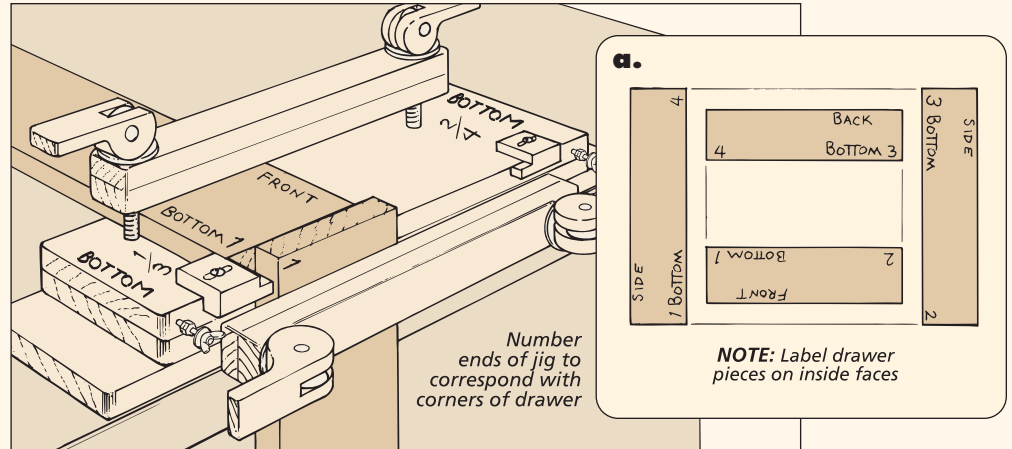

and half on the right side. Shop Tip: To help myself keep straight which corner goes where, I also label the ends of the jig, see drawing above.

ROUT FIRST CORNER. To rout the first corner, place the drawer side in the front of the jig and the drawer front on the top of the jig, just like you did with the test pieces. Make sure the pieces are against the stops and the clamps are tightened securely. Then rout the dovetails.

At this point, you've routed the joint at the left front corner of the drawer (No. 1). Next, rout the right rear cor-

ner joint (No. 3) using the same procedure. (Place the drawer back piece on the top of the jig.)

The other two joints (Nos. 2 and 4) are routed with the pieces tight against the stop block on the *right* side of the jig.

When routing on the right side of the jig, follow the same procedure. Make a scoring pass from right to left and then move the router in and out of the notches from left to right.

Now it's just a matter of repeating this process to cut the dovetails on the remainder of the drawers. **W**

TESTING THE FIT



Setting up to rout machine-cut dovetails is always a trial and error effort. There's usually lots of fiddling around with test pieces and adjusting of the jig to get a perfect fit.

TOO LOOSE. If the joint is so loose that the pieces wiggle around when they're put together, the depth of cut is too shallow, see first photo. Increase the depth of cut about $\frac{1}{32}$ " and try again.

TOO TIGHT. If a trial cut is so tight that the pieces can't be tapped together, the router bit is extended out too far from the router base. Decrease the depth of cut about $\frac{1}{32}$ " and try again.

TOO DEEP. If the pins on the drawer sides go too far into the sockets on the drawer front, the sockets are too deep, see

middle photo below. To correct this, move the template forward (toward you) by turning the stop nuts on the studs counterclockwise. (Be sure to adjust the nuts on both ends of the jig.)

TOO SHALLOW. If the pins don't go far enough into the sockets, move the template back (away from you) by turning the stop nuts clockwise.

OFFSET. If the top edges of the two pieces

aren't flush when you assemble the joint, the problem is either with the offset of the stop blocks (it should be $\frac{7}{16}$ ") or the fact that the pieces weren't tight against the stops, see third photo.

OTHER PROBLEMS. Most other problems are usually caused by the pieces not being clamped down in the jig so they are flush across the top, or because they move out of position as they're being routed.



Too Loose. If joint is too loose, increase bit depth.

Too Tight. If the joint is too tight, decrease depth.



Too Deep. If pins go deep, move template forward.

Too Shallow. If not deep enough, move back.



Offset. If the pieces don't align at top or bottom, they may not have been tight against stops.